

# **GYRO™** Bin Activating Feeder



The GYRO™ bin activating feeder produces 360 degrees of pure gyratory motion to positively and more reliably discharge granular materials from bins, storage silos and hoppers at any desired feed rate.

At the heart of the GYRO bin activating feeder is the drive that produces 360 degrees of radial force creating a uniform circular motion on all parts of the feeder. It is this annular radial vibratory motion which imparts the ultimate force, assuring a constant and reliable material flow. This also minimizes any material stratification in the storage silo or bin and develops a predictable and positive flow of material upon demand.

A unique feature of the GYRO bin activating feeder is that the silo or bin head of material is completely supported by the upper activation cone, thus assuring a positive cut-off of material flow when the feeder is deactivated. The feeder can also be started and stopped as required and material will not accumulate in the lower discharge cone, eliminating packing or plugging problems. The GYRO bin activating feeder is well suited for almost any dry bulk granular material, irrespective of particle size and/or bulk density.

In addition, the GYRO bin activating feeder can operate either continuously or as a start and stop operation as might be required for more sophisticated process applications. Also available is an optional variable speed drive, which provides a variable material discharge rate with up to a 400 to 1 turndown ratio for batch weighing operations. Thus high accuracy of individual weightings can be achieved quickly for process efficiency and for precise feeding and bin discharging of almost any material.

## **Features**

- Uniform material feeding
- Infinitely adjustable feed rates
- Reliable material discharge
- Prevents material segregation
- Prevents material from compacting
- Extremely low headroom allows for more material storage
- Eliminates the need for additional equipment such as discharge gates or feeders
- Positive material cut-off
- Effective on large or small particles
- Low power requirements

# **GYRO** Bin Activating Feeder Design Features

- A.** Minimal height due to feeding principle.
- B.** Cone angle can be very shallow as clogging is not an issue.
- C.** Material stops due to angle of repose.
- D.** Material is not allowed to consolidate in lower cone.
- E.** Gap is adjustable to increase or decrease feed rate.

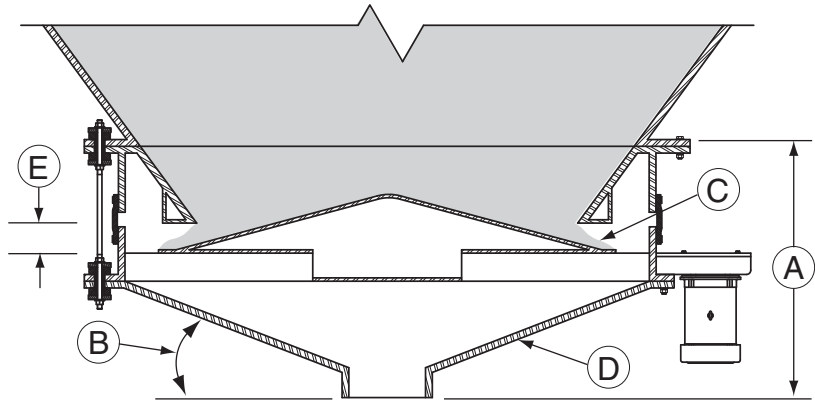

**GYRO Bin Activating Feeder at Rest Position**

- F.** Stored material does not put any stress on flexible connector, providing longer life.
- G.** Circular distance of activation cone creates a wide feed zone.
- H.** Circular motion of lower cone acts like a vibratory feeder and empties completely without material compaction or consolidation.

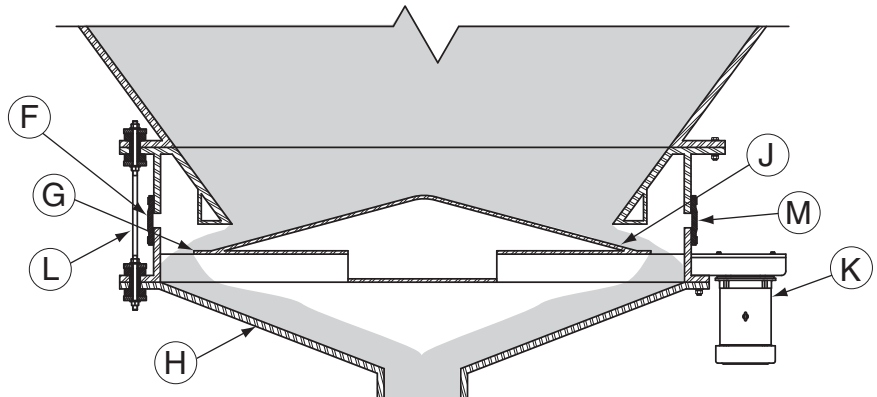

**GYRO Bin Activating Feeder during Discharge Cycle**

- J.** Activation cone provides even distribution of the forces for a consistent flow.
- K.** Standard inexpensive motor.
- L.** High strength support rods with rubber isolators to maximize gyration.
- M.** High strength reinforced flexible connector with stainless steel band clamps to insure a dust-tight connection.

# How the **GYRO** Bin Activating Feeder Works

The GYRO bin activating feeder uses a standard motor with adjustable counter weights to generate a gyratory motion for feeding dry granular material from bins, hoppers and storage silos for a controlled feed and/or discharge. The GYRO bin activating feeder can be controlled for fast and slow feed with as much as a 400 to 1 turndown ratio using a variable speed drive.

When the GYRO bin activating feeder is in the rest or deactivated position, the lower cone area is empty of material and the angle of repose of the stored material keeps it from moving into the lower cone area.

When the GYRO bin activating feeder is turned on or activated, the force generated by the counter weight creates a tangential or circular motion which is imparted to the upper activation cone and to the

lower discharge cone. The circumferential distance of the upper activation cone now becomes the actual length of the feeder itself, so it has the benefit of a large feeding width in a small area. For weighing and batching applications, the GYRO bin activating feeder can be stopped instantly for the ultimate in weighing accuracy.

Because the lower discharge cone has a greater discharge angle than the upper activation cone, the material will discharge from the lower discharge cone area much faster, thus improving material flow. In addition, the GYRO bin activating feeder also minimizes and/or eliminates any material buildup in the lower discharge cone area and prevents any compaction from occurring, because material is never allowed to stagnate and is always kept moving towards the outlet until the lower discharge cone empties completely.

### GYRO Bin Activating Feeder Nominal Capacity Chart

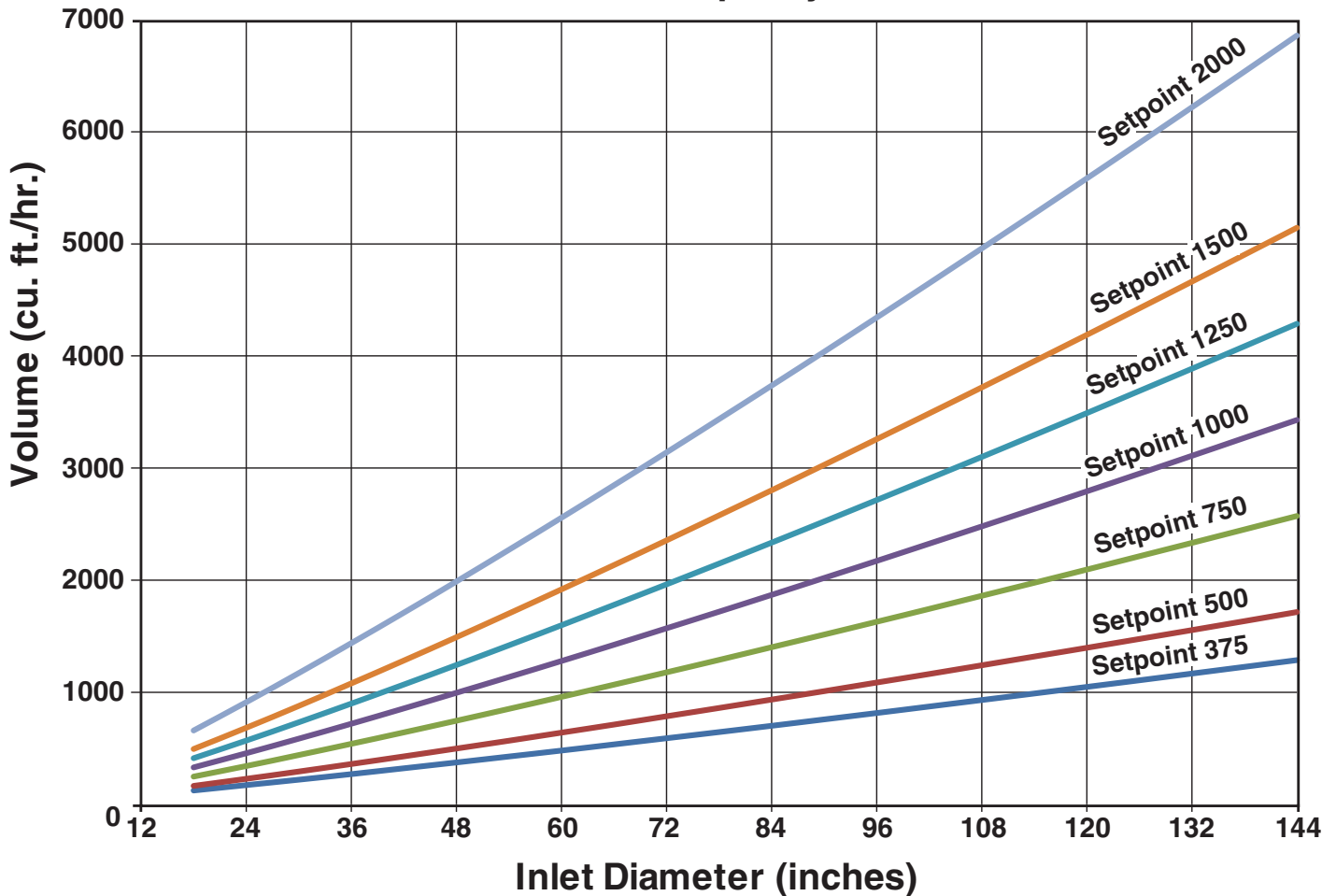

*The above capacities are general in nature; testing is required to verify specific data.*

# GYRO Bin Activating Feeder Dimensions & Specifications

Model	GYRO Bin Activating Feeder Dimensions in inches (mm)										Approx. Ship Weight lbs (kg)
	A	B	C	D*	E	F	G	H	J	Motor HP**	
G-180	24 (610)	18 (457)	17 (432)	6 (152)	0.63 (16)	21 (533)	22 (559)	12	8 (203)	1/3	240 (109)
G-240	30 (762)	24 (610)	19 (483)	6 (152)	0.63 (16)	27 (686)	25 (635)	15	8 (203)	1/3	400 (181)
G-300	36 (914)	30 (762)	20 (508)	6 (152)	0.63 (16)	33 (838)	28 (711)	19	8 (203)	1/2	550 (249)
G-360	42 (1067)	36 (914)	21 (533)	6 (152)	0.75 (19)	39 (991)	31 (787)	22	8 (203)	1/2	700 (318)
G-480	56 (1422)	48 (1219)	23 (584)	6 (152)	0.75 (19)	52 (1321)	37 (940)	30	8 (203)	1	1050 (476)
G-600	68 (1727)	60 (1524)	25 (635)	8 (203)	0.75 (19)	64 (1626)	43 (1092)	37	8 (203)	1	1500 (680)
G-720	84 (2134)	72 (1829)	33 (838)	10 (254)	0.75 (19)	78 (1981)	49 (1245)	45	8 (203)	2	1950 (885)
G-840	96 (2438)	84 (2134)	35 (889)	10 (254)	0.75 (19)	90 (2286)	55 (1397)	51	8 (203)	3	2450 (1111)
G-960	108 (2743)	96 (2438)	37 (940)	12 (305)	0.88 (22)	102 (2591)	61 (1549)	58	8 (203)	5	3025 (1372)
G-1080	120 (3048)	108 (2743)	39 (991)	12 (305)	0.88 (22)	114 (2896)	67 (1702)	65	12 (305)	5	3520 (1597)
G-1200	132 (3353)	120 (3048)	41 (1041)	12 (305)	0.88 (22)	126 (3200)	73 (1854)	72	12 (305)	5	4300 (1950)

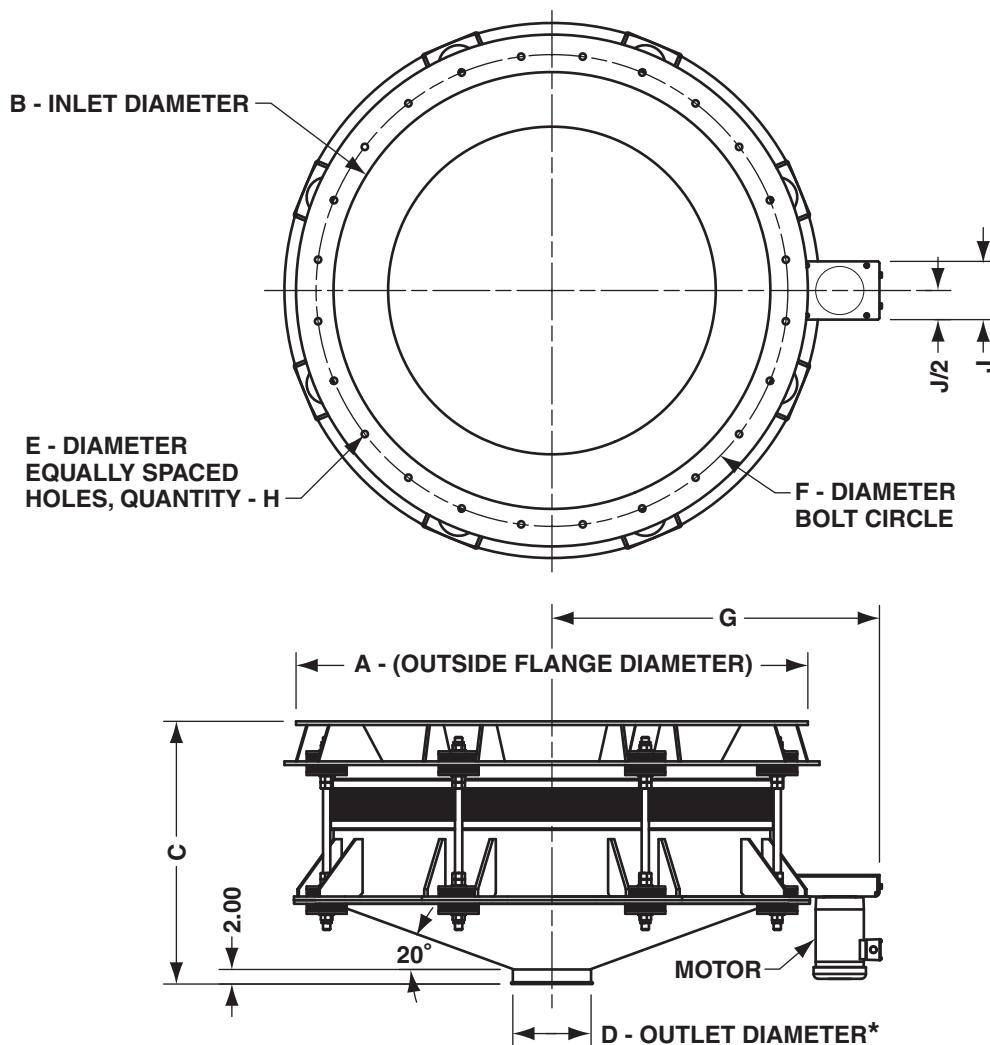

\* Custom outlet sizes available. \*\* Application dependent.  
 Dimensions and specifications subject to change without notice.  
 Dynamic Air Conveying Systems® and GYRO™ are trademarks  
 of Dynamic Air Inc., St. Paul, Minnesota.

U.S. and Foreign Patents Pending  
 © 2018, Dynamic Air Inc.  
 Bulletin K041906-8 (dm2) • Printed in the USA

**DYNAMIC AIR**®  
 Conveying Systems

**Corporate Headquarters**  
 Dynamic Air Inc. • St. Paul, MN USA • +1 651 484-2900  
**Worldwide Offices**  
 Brazil • China • United Kingdom  
[www.dynamicair.com](http://www.dynamicair.com)